

SOLENOID VALVE FOR REFRIGERATING SYSTEMS

FROM QUALITY OUR NATURAL DEVELOPMENT

Achieved the goal of fifty years working in the industry of Refrigeration and Air Conditioning, Castel Quality Range of Products is well known and highly appreciated all over the world. Quality is the main issue of our Company and it has a special priority, in every step, all along the production cycle. UNI EN ISO 9001:2008, issued by ICIM, certifies the Quality System of the Factory. Moreover Castel Products count a number of certifications in conformity with EEC Directives and with European and American Quality Approval.

We produce on high tech machinery and updated automatic production lines, operating in conformity with the safety and environment standards currently enforced.

Castel offers to the Refrigeration and Air Conditioning Market and to the Manufacturers fully tested products suitable with HCFC and HFC Refrigerants currently used in the Refrigeration & Air Conditioning Industry.

July 2011

INDEX

Solenoid valves, normally closed and normally open	pag 5
Coils	pag 15
Connectors	pag 18
Permanent magnet	pag 19

EXTERNAL LEAKAGE

All the products illustrated in this Handbook are submitted, one by one, to tightness tests besides to functional tests. Allowable external leakage, measurable during the test, agrees to the definition given in Par. 9.4 of EN 12284 : 2003 Standard:

"During the test, no bubbles shall form over a period of at least one minute when the specimen is immersed in water with low surface tension, ..."

PRESSURE CONTAINMENT

All the products illustrated in this Handbook, if submitted to hydrostatic test, guarantee a pressure strength at least equal to 1,43 x PS in compliance with the Directive 97/23/EC.

All the products illustrated in this Handbook, if submitted to burst test, guarantee a pressure strength at least equal to 3 x PS according to EN 378-2 : 2008 Standard.

WEIGHTS

The weights of the items listed in this Handbook include packaging.

GUARANTEE

All Castel products are covered by a 12 - months warranty. This warranty covers all products or parts thereof that turn out to be defective within the warranty period. In this case, at his own expenses, the customer shall return the defective item with a detailed description of the claimed defects. The warranty doesn't apply if the defect of Castel products are due to mistakes either by customer or by third parties such wrong installations, use contrary to Castel indications, tampering. In case of defects of its own products, Castel will only replace the defective goods and will not refund damages of any kind.

The technical data shown on this catalogue are indicative. Castel reserves the right to modify the same at any time without any previous notice.

The products listed in this handbook are protected according to the law.

SOLENOID VALVES, NORMALLY CLOSED AND NORMALLY OPEN



APPLICATIONS

The solenoid valves, shown in this handbook, are classified "Pressure accessories" in the sense of the Pressure Equipment Directive 94/23/EC, Article 1, Section 2.1.4 and are subject of Article 3, Section 1.3 of the same Directive.

They are designed for installation on commercial refrigerating systems and on civil and industrial conditioning plants, which use the following refrigerant fluids: R22, R134a, R404A, R407C, R410A; R507 proper to the Group II (as defined in Article 9, Section 2.2 of Directive 97/23/EC and referred to in Directive 67/548/EEC). For specific applications with refrigerant fluids not listed above, always proper to the Group II, please contact Castel Technical Department.

OPERATION

The valves series 1020; 1028; 1034; 1038; 1040; 1048; 1049; 1050; 1058; 1059; 1064; 1068; 1070; 1078; 1079; 1090; 1098; 1099 are normally closed valves.

NC = when the coil is de-energised the plunger stops the fluid flow, when the coil is electrically energised the plunger opens the valve seat connecting the inlet to the outlet.

The NC valves are supplied either without coil (S type) or with coil (ex. : A6 type with coil HM2-220 V AC).

The valves series 1134; 1138; 1140; 1148; 1150; 1158; 1164; 1168; 1170; 1178; 1190; 1198 are normally open valves.

NO = when the coil is de-energised the plunger opens the valve seat connecting the inlet to the outlet, when the coil is electrically energised the plunger stops the fluid flow.

The NO valves are supplied only without coil (S type).

N.B.: the NO valve visually differs from the corresponding NC model by

means of the red ring installed below the yellow nut that fastens the coil.

The valves series 1020 and 1028 are **direct acting valves**. The operation depends only on the magnetic field produced by the current flow into the coil. Opening/closing of main valve seat, the only seat, is directly controlled by the mobile plunger and the valves can open with zero pressure differential.

The NC valves series 1064; 1068; 1070; 1078 (excluded /11, /13, /M42); 1079 (excluded /13, /M42, /17); 1090; 1098 (excluded /9); 1099 (excluded /11) e the NO valves series 1164; 1168; 1170; 1178 (excluded /11, /13, /M42); 1190; 1198 (excluded /9) are **diaphragm pilot operated valves**.

The operation depends not only on the magnetic field produced by the current flow into the coil but it's also necessary a minimum inlet pressure to move the diaphragm and to keep it lift off the main seat. Opening/closing of main seat is controlled by the diaphragm while opening/closing of pilot seat is controlled by the mobile plunger. These valves cannot work with zero pressure differential.

The NC valves series 1034; 1038; 1040; 1048; 1049; 1050; 1058; 1059; 1078 (/11, /13, /M42); 1079 (/13, /M42, /17); 1098/9; 1099/11 e the NO valves series 1134; 1138; 1140; 1148; 1150; 1158; 1178 (/11, /13, /M42); 1198/9 are **piston pilot operated valves**.

The operation depends not only on the magnetic field produced by the current flow into the coil but it's also necessary a minimum inlet pressure to move the piston and to keep it lift off the main seat. Opening/closing of main seat is controlled by the piston while opening/closing of pilot seat is controlled by the mobile plunger. These valves cannot work with zero pressure differential.

CONSTRUCTION

The main parts of the valves are made with the following materials:

- Hot forged brass EN 12420 – CW 617N for body and cover
- Copper tube EN 12735-1 – Cu-DHP for solder connections
- Austenitic stainless steel EN 10088-2 – 1.4303 for enclosure where the plunger moves
- Ferritic stainless steel EN 10088-3 – 1.4105 for plunger
- Austenitic stainless steel EN ISO 3506 – A2-70 for tightening screws between body and cover
- Chloroprene rubber (CR) for outlet seal gaskets
- P.T.F.E. for seat gaskets

INSTALLATION

The valves can be installed in all sections of a refrigerating system, in compliance with the limits and capacities indicated in Tables 3 and 6. Castel recommends using piston valves in those applications with hard operating conditions (temperature/pressure), for example in hot gas line.

Tables 1 and 4 show the following functional characteristics of a solenoid valve:

- PS : maximum allowable pressure
- TS : maximum / minimum allowable temperature
- Kv : discharge factor
- minOPD : minimum Opening Pressure Differential. That is the minimum pressure differential between inlet and outlet at which a solenoid valve, pilot operated, can open and stay opened.
- MOPD : maximum Opening Pressure Differential according to ARI STANDARD 760 : 2001. That is the maximum pressure differential between inlet and outlet at which a solenoid valve, pilot operated, can open.

Before connecting the valve to the pipe it is advisable to make sure that the refrigerating system is clean. In fact valves with P.T.F.E. gaskets, and particularly piston valves, are sensitive to dirt and debris. Furthermore check that the flow direction in the pipe corresponds to the arrow stamped on the body of the valve. All the valves can be mounted in



TABLE 1A: General Characteristics of NC valves (normally closed) with SAE Flare connections

Operating Principles	Catalogue Number	SAE Flare Connections	Seat size nominal Ø [mm]	Kv Factor [m³/h]	Opening Pressure Differential [bar]			TS [°C]		PS [bar]	Risk Category according to PED	
					min OPD	MOPD			min.			max.
						Coil type						
						HM2 CM2 (AC)	HM4 (AC)	HM3 (DC)				
Direct Acting	1020/2	1/4"	2.5	0.18	0	21	25	19	- 35	+110 (2)	45	Art. 3.3
	1020/3	3/8"	3	0.23								
Diaphragm Pilot Operated	1064/3	3/8"	6.5	0.80	0.05	21	25	19	- 35	+105 (1)	45	Art. 3.3
	1064/4	1/2"										
	1070/4	1/2"	2.20									
	1070/5	5/8"		2.61								
	1090/5	5/8"	3.80									
	1090/6	3/4"		4.80				21				
Piston Pilot Operated	1034/3	3/8"	6.5	1.00	0.05	21	25	19	- 35	+110 (2)	45	Art. 3.3
	1034/4	1/2"										
	1040/4	1/2"	2.40									
	1040/5	5/8"		3.00								
	1050/5	5/8"	3.80									
	1050/6	3/4"		4.80				21				

(1) Temperature peaks of 120 °C are allowed during defrosting

(2) Temperature peaks of 130 °C are allowed during defrosting

(3) For higher MOPD it's available coil type 9120/RA6 (HM3 220/230 AC). For further information please contact Castel Technical Department.

TABLE 1B: General Characteristics of NC valves (normally closed) with ODS connections

Operating Principles	Catalogue Number	Connections ODS		Seat size nominal Ø [mm]	Kv Factor [m³/h]	Opening Pressure Differential [bar]				TS [°C]		PS [bar]	Risk Category according to PED
		Ø [in.]	Ø [mm]			min OPD	MOPD (3)			min.	max.		
							Coil type						
		HM2 CM2 (AC)	HM4 (AC)				HM3 (DC)						
Direct Acting	1028/2	1/4"	–	2.2	0.15	0	21	25	19	– 35	+110 (2)	45	Art. 3.3
	1028/2E	1/4"	–	3	0.23								
	1028/3	3/8"	–										
	1028/M10	–	10										
Diaphragm Pilot Operated	1068/3	3/8"	–	6.5	0.80	0.05	21	25	19	– 35	+105 (1)	45	Art. 3.3
	1068/M10	–	10										
	1068/M12	–	12										
	1068/4	1/2"	–	12.5	2.20								
	1078/M12	–	12										
	1078/4	1/2"	–										
	1078/5	5/8"	16	16.5	2.61								
	1079/7	7/8"	22										
	1098/5	5/8"	16										
	1098/6	3/4"	–	25.5	10								
	1098/7	7/8"	22										
	1099/9	1.1/8"	–										
	1078/9	1.1/8"	–	6.5	1.00								
	1079/11	1.3/8"	35										
1038/3	3/8"	–											
Piston Pilot Operated	1038/M10	–	10	12.5	2.40	0.07	21	25	19	– 35	+110 (2)	45	Art. 3.3
	1038/M12	–	12										
	1038/4	1/2"	–										
	1048/M12	–	12	16.5	3.80								
	1048/4	1/2"	–										
	1048/5	5/8"	16										
	1049/7	7/8"	22	25	10								
	1058/5	5/8"	16										
	1058/6	3/4"	–										
	1058/7	7/8"	22	27	16								
	1059/9	1.1/8"	–										
	1098/9	1.1/8"	–										
	1099/11	1.3/8"	35	34	25								
	1078/11	1.3/8"	35										
	1079/13	1.5/8"	–										
	1079/M42	–	42	34	25								
	1078/13	1.5/8"	–										
	1078/M42	–	42										
	1079/17	2.1/8"	54						0.1				

(1) Temperature peaks of 120 °C are allowed during defrosting

(2) Temperature peaks of 130 °C are allowed during defrosting

(3) For higher MOPD it's available coil type 9120/RA6 (HM3 220/230 AC). For further information please contact Castel Technical Department.

whatever position except with the coil pointing downwards. The brazing of valves with solder connections should be carried out with care, using a low melting point filler material. It is not necessary to disassemble the valves before brazing but it's important to avoid direct contact between the torch flame and the valve body, which could be damaged and compromise the proper functioning of the valve.

Before connecting a valve to the electrical system, be sure that the line voltage and frequency correspond to the values marked on the coil.

The NO valves have been designed to work only with direct current coils; to use them in applications with 220/230 VAC supply it's necessary to mate the NO valve with the following components: Coil 9120/RD6 + Connector/Rectifier 9150/R45

TABLE 2: Dimensions and Weights of NC valves with 9100 coils (1)

Operating Principles	Catalogue Number	Dimensions [mm]						Weight [g]
		H1	H2	H3	L1	L2	Q	
Direct Acting	1020/2	75	62.5	34	58	50	-	340
	1020/3				65			355
	1028/2				125			350
	1028/2E				125			350
	1028/3				125			365
	1028/M10				125			365
Diaphragm Pilot Operated	1064/3	82	69.5	40	68	50	-	400
	1064/4				72			415
	1068/3				111			400
	1068/M10				111			395
	1068/M12				127			420
	1068/4				127			420
	1070/4	91	75	47	100		45	710
	1070/5				106			755
	1078/M12				127			690
	1078/4				127			680
	1078/5				175			775
	1079/7				190			765
	1090/5	106	78	50	120		57	1035
	1090/6				124			1365
	1098/5				175			995
	1098/6				175			1185
	1098/7				180			1170
	1099/9				216			1225
	1078/9	115	96	72	250		80	2565
	1079/11				292			2620
Piston Pilot Operated	1034/3	92.5	80	50.5	68	50	-	440
	1034/4				72			457
	1038/3				111			440
	1038/M10				111			435
	1038/M12				127			462
	1038/4				127			462
	1040/4	100.5	84.5	56.5	100		45	781
	1040/5				106			831
	1048/M12				127			759
	1048/4				127			748
	1048/5				175			853
	1049/7				190			842
	1050/5	121	93	65	120		57	1157
	1050/6				124			1487
	1058/5				175			1117
	1058/6				175			1307
	1058/7				180			1292
	1059/9				216			1347
	1098/9	157	127	99	235		68	2050
	1099/11				277			2130
	1078/11	175	141	113	278		80	2710
	1079/13							2750
	1079/M42							2750
1078/13	190	153	125	280	88	3810		
1078/M42						3810		
1079/17						3880		

(1) : With coil 9120 the dimension L2 is equal to 64 mm and the weights must be increased of 305 g. Connectors are not included in the boxes and have to be ordered separately

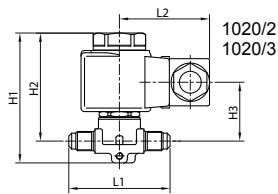

1020/2
1020/3

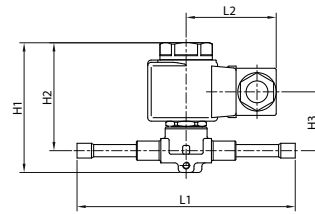

1028/2
1028/3
1028/M10

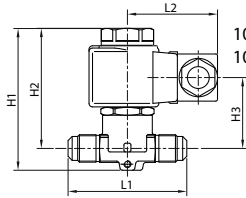

1034/3 1064/3
1034/4 1064/4

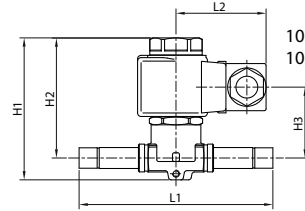

1038/3 1068/3 1038/M10 1068/M10
1038/4 1068/4 1038/M12 1068/M12

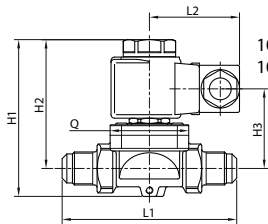

1040/4 1070/4
1040/5 1070/5

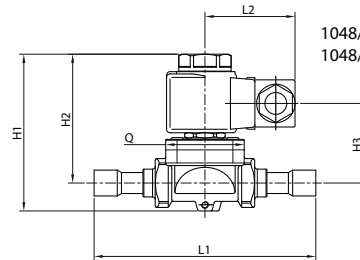

1048/M12 1078/M12 1048/5 1078/5
1048/4 1078/4 1049/7 1079/7

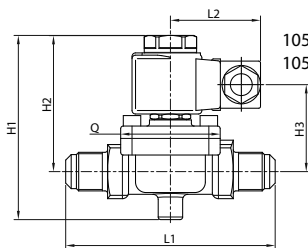

1050/5 1090/5
1050/6 1090/6

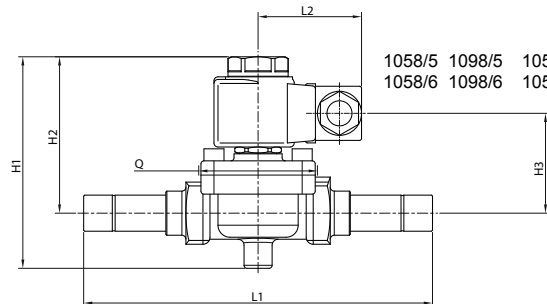

1058/5 1098/5 1058/7 1098/7
1058/6 1098/6 1058/9 1098/9

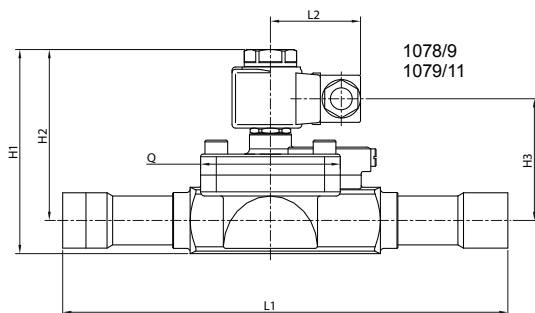

1078/9
1079/11

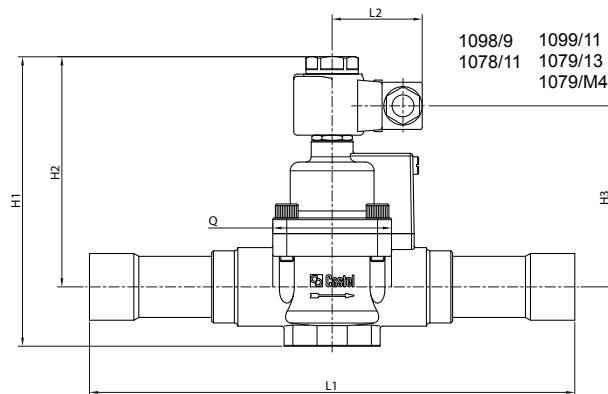

1098/9 1099/11 1078/13
1078/11 1079/13 1078/M42
1079/M42 1079/17

TABLE 3: Refrigerant Flow Capacity of NC valves [kW]

Operating Principles	Catalogue Number	Liquid line						Suction line						Hot Gas line						
		R134a	R22	R404A	R407C	R410A	R507	R134a	R22	R404A	R407C	R410A	R507	R134a	R22	R404A	R407C	R410A	R507	
Direct Acting	1020/2	2.98	3.20	2.08	3.02	3.00	2.01							1.49	1.89	1.68	2.03	2.38	1.67	
	1020/3	3.91	4.21	2.74	3.96	3.95	2.65							1.96	2.48	2.21	2.67	3.13	2.19	
	1028/2	2.55	2.75	1.79	2.58	2.58	1.73							1.28	1.62	1.44	1.74	2.04	1.43	
	1028/2E							-	-	-	-	-	-							
	1028/3	3.91	4.21	2.74	3.96	3.95	2.65							1.96	2.48	2.21	2.67	3.13	2.19	
	1028/M10																			
Diaphragm Pilot Operated	1064/3																			
	1064/4																			
	1068/3	13.6	14.6	9.5	13.8	13.7	9.2	1.51	2.04	1.78	1.82	2.40	1.78	6.8	8.6	7.7	9.3	10.9	7.6	
	1068/M10																			
	1068/M12																			
	1068/4																			
	1070/4	37.4	40.3	26.2	37.9	37.8	25.3	4.16	5.61	4.91	4.99	6.60	4.91	18.7	23.8	21.1	25.6	29.9	21.0	
	1070/5	44.4	47.8	31.1	45.0	44.8	30.0	4.93	6.66	5.82	5.92	7.83	5.82	22.2	28.2	25.1	30.3	35.5	24.9	
	1078/M12																			
	1078/4	37.4	40.3	26.2	37.9	37.8	25.3	4.16	5.61	4.91	4.99	6.60	4.91	18.7	23.8	21.1	25.6	29.9	21.0	
	1078/5	44.4	47.8	31.1	45.0	44.8	30.0	4.93	6.66	5.82	5.92	7.83	5.82	22.2	28.2	25.1	30.3	35.5	24.9	
	1079/7																			
	1090/5	64.6	69.5	45.2	65.5	65.2	43.7	7.2	9.7	8.5	8.6	11.4	8.5	32.3	41.0	36.5	44.2	51.7	36.3	
	1090/6	81.6	87.8	57.1	82.7	82.4	55.2	9.1	12.2	10.7	10.9	14.4	10.7	40.8	51.8	46.1	55.8	65.3	45.8	
	1098/5	64.6	69.5	45.2	65.5	65.2	43.7	7.2	9.7	8.5	8.6	11.4	8.5	32.3	41.0	36.5	44.2	51.7	36.3	
	1098/6	81.6	87.8	57.1	82.7	82.4	55.2	9.1	12.2	10.7	10.9	14.4	10.7	40.8	51.8	46.1	55.8	65.3	45.8	
	1098/7																			
	1099/9	96.9	104.3	67.8	98.2	97.9	65.6	10.8	14.5	12.7	12.9	17.1	12.7	48.5	61.6	54.7	66.2	77.5	54.4	
	1078/9																			
	1079/11	170.0	183.0	119.0	172.3	171.7	115.0	18.9	25.5	22.3	22.7	30.0	22.3	85.0	108.0	96.0	116.2	136.0	95.4	
Piston Pilot Operated	1034/3																			
	1034/4																			
	1038/3	17.0	18.3	11.9	17.2	17.2	11.5	1.89	2.55	2.23	2.27	3.00	2.23	8.5	10.8	9.6	11.6	13.6	9.5	
	1038/M10																			
	1038/M12																			
	1038/4																			
	1040/4	40.8	43.9	28.6	41.4	41.2	27.6	4.54	6.12	5.35	5.45	7.20	5.35	20.4	25.9	23.0	27.9	32.6	22.9	
	1040/5	51.0	54.9	35.7	51.7	51.5	34.5	5.67	7.65	6.69	6.81	9.00	6.69	25.5	32.4	28.8	34.9	40.8	28.6	
	1048/M12																			
	1048/4	40.8	43.9	28.6	41.4	41.2	27.6	4.54	6.12	5.35	5.45	7.20	5.35	20.4	25.9	23.0	27.9	32.6	22.9	
	1048/5																			
	1049/7	51.0	54.9	35.7	51.7	51.5	34.5	5.67	7.65	6.69	6.81	9.00	6.69	25.5	32.4	28.8	34.9	40.8	28.6	
	1050/5	64.6	69.5	45.2	65.5	65.2	43.7	7.2	9.7	8.5	8.6	11.4	8.5	32.3	41.0	36.5	44.2	51.7	36.3	
	1050/6	81.6	87.8	57.1	82.7	82.4	55.2	9.1	12.2	10.7	10.9	14.4	10.7	40.8	51.8	46.1	55.8	65.3	45.8	
	1058/5	64.6	69.5	45.2	65.5	65.2	43.7	7.2	9.7	8.5	8.6	11.4	8.5	32.3	41.0	36.5	44.2	51.7	36.3	
	1058/6	81.6	87.8	57.1	82.7	82.4	55.2	9.1	12.2	10.7	10.9	14.4	10.7	40.8	51.8	46.1	55.8	65.3	45.8	
	1058/7																			
	1059/9	96.9	104.3	67.8	98.2	97.9	65.6	10.8	14.5	12.7	12.9	17.1	12.7	48.5	61.6	54.7	66.2	77.5	54.4	
	1098/9																			
	1099/11	170.0	183.0	119.0	172.3	171.7	115.0	18.9	25.5	22.3	22.7	30.0	22.3	85.0	108.0	96.0	116.2	136.0	95.4	
1078/11																				
1079/13	272.0	292.8	190.4	275.7	274.7	184.0	30.2	40.8	35.7	36.3	48.0	35.7	136.0	172.8	153.6	185.9	217.6	152.6		
1079/M42																				
1078/13																				
1078/M42	425.0	457.5	297.5	430.8	429.3	287.5	47.3	63.8	55.8	56.8	75.0	55.8	212.5	270.0	240.0	290.5	340.0	238.5		
1079/17																				

Standard rating conditions according to AHRI Standard 760-2007

Condensing temperature 110 °F (43,3 °C)
 Liquid temperature 100 °F (37,8 °C)
 Subcooling 10 °R (5,5 °K)

Evaporating temperature 40 °F (4,4 °C)
 Suction temperature 65 °F (18,3 °C)
 Superheating 25 °R (13,9 °K)

Discharge temperature 160 °F (71,1 °C)

TABLE 4A: General Characteristics of NO valves (normally open) with SAE Flare connections										
Operating Principles	Catalogue Number	SAE Flare Connections	Seat size nominal Ø [mm]	Kv Factor [m³/h]	Opening Pressure Differential [bar]		TS [°C]		PS [bar]	Risk Category according to PED
					min OPD	MOPD	min.	max.		
Diaphragm Pilot Operated	1164/3	3/8"	6.5	0.80	0.05	21	- 35	+105 (1)	45	Art. 3.3
	1170/4	1/2"	12.5	2.20						
	1170/5	5/8"		2.61						
	1190/5	5/8"	16.5	3.80						
	1190/6	3/4"		4.80						
Piston Pilot Operated	1134/3	3/8"	6.5	1.00	0.07	21	- 35	+110 (2)	45	Art. 3.3
	1140/4	1/2"	12.5	2.40						
	1140/5	5/8"		3.00						
	1150/5	5/8"	16.5	3.80						
	1150/6	3/4"		4.80						

(1) Temperature peaks of 120 °C are allowed during defrosting

(2) Temperature peaks of 130 °C are allowed during defrosting

TABLE 4B: General Characteristics of NO valves (normally open) with ODS connections											
Operating Principles	Catalogue Number	Connections ODS		Seat size nominal Ø [mm]	Kv Factor [m³/h]	Opening Pressure Differential [bar]		TS [°C]		PS [bar]	Risk Category according to PED
		Ø [in.]	Ø [mm]			min OPD	MOPD	min.	max.		
Diaphragm Pilot Operated	1168/3	3/8"	-	6.5	0.80	0.05	21	- 35	+105 (1)	45	Art. 3.3
	1168/M10	-	10								
	1178/M12	-	12								
	1178/4	1/2"	-	12.5	2.20						
	1178/5	5/8"	16								
	1198/5	5/8"	16	16.5	3.80						
	1198/6	3/4"	-								
	1198/7	7/8"	22								
	1178/9	1.1/8"	-	25.5	10						
Piston Pilot Operated	1138/3	3/8"	-	6.5	1.00	0.07	21	- 35	+110 (2)	45	Art. 3.3
	1138/M10	-	10								
	1148/M12	-	12								
	1148/4	1/2"	-	12.5	2.40						
	1148/5	5/8"	16								
	1158/5	5/8"	16	16.5	3.80						
	1158/6	3/4"	-								
	1158/7	7/8"	22								
	1198/9	1.1/8"	-	25	10						
	1178/11	1.3/8"	35	27	16						
	1178/13	1.5/8"	-	34	25						
	1178/M42	-	42								

(1) Temperature peaks of 120 °C are allowed during defrosting

(2) Temperature peaks of 130 °C are allowed during defrosting

TABLE 5: Dimensions and Weights of NO valves with 9120 coils

Operating Principles	Catalogue Number	Dimensions [mm]						Weight [g]
		H1	H2	H3	L1	L2	Q	
Diaphragm Pilot Operated	1164/3	87	74.5	40	68	50	-	705
	1168/3				111			705
	1168/M10				111			700
	1170/4	96	80	47	100		45	1015
	1170/5				106			1060
	1178/M12				127			995
	1178/4				127			985
	1178/5				175			1080
	1190/5	111	83	50	120		57	1340
	1190/6				124			1670
	1198/5				175			1300
	1198/6				175			1490
	1198/7				180			1475
	1178/9	120	101	72	250		80	2870
	Piston Pilot Operated	1134/3	97.5	85	50.5		68	50
1138/3		111				775		
1138/M11		111				770		
1140/4		105.5	89.5	56.5	100	45	1117	
1140/5					106		1166	
1148/M12					127		1095	
1148/4					127		1084	
1148/5					175		1188	
1150/5		126	98	70	120	57	1462	
1150/6					124		1792	
1158/5					175		1422	
1158/6					175		1612	
1158/7					180		1597	
1198/9		162	132	99	235	68	2355	
1178/11		180	146	113	278	80	3015	
1178/13		195	158	130	28	88	3820	
1178/M42							3820	

Connectors are not included in the boxes and have to be ordered separately

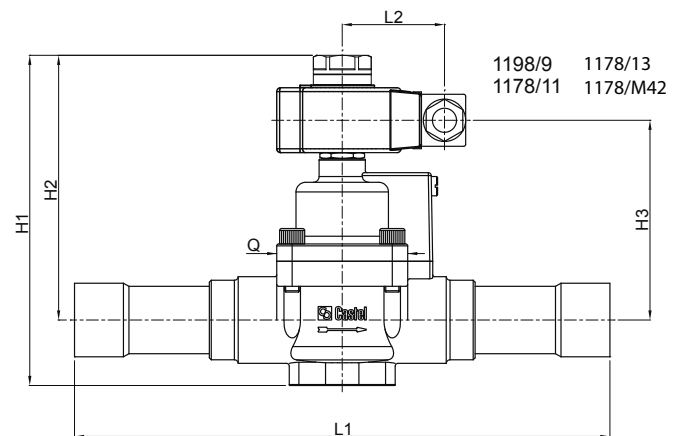
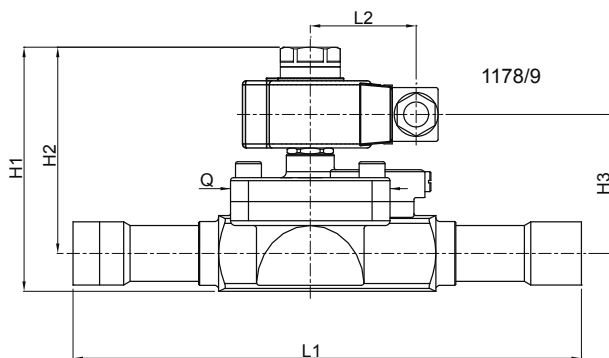
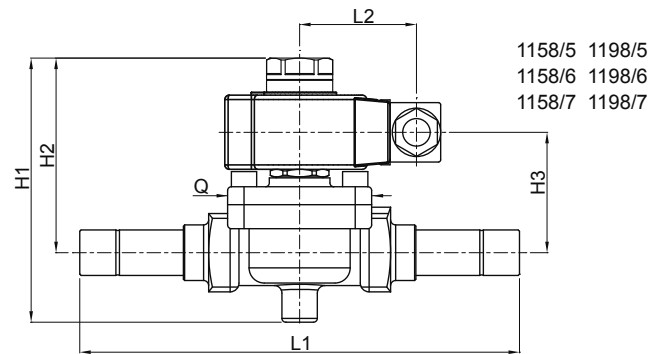
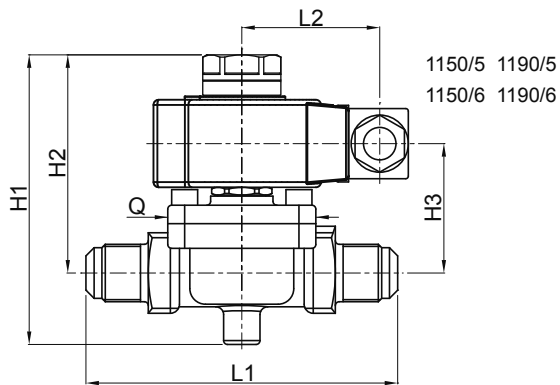
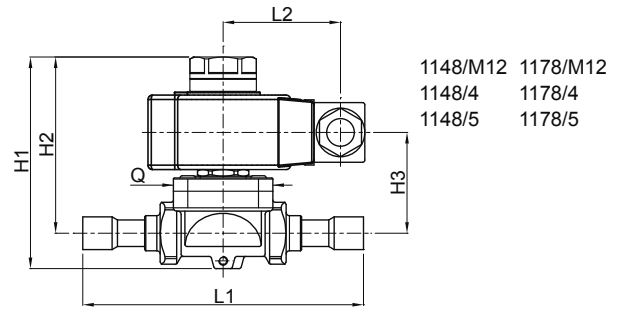
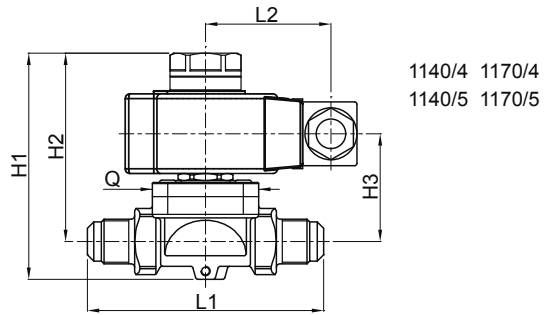
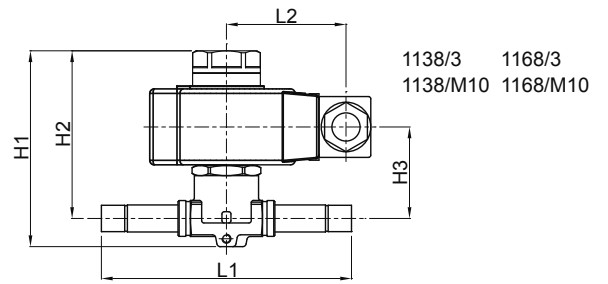
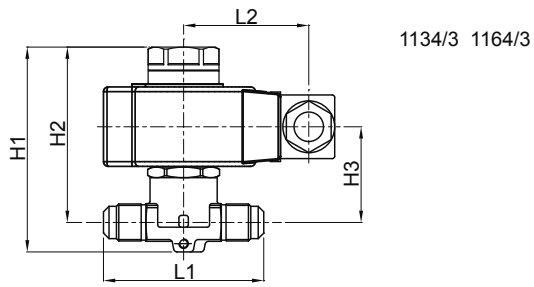

TABLE 6: Refrigerant Flow Capacity of NO valves [kW]

Operating Principles	Catalogue Number	Liquid line						Suction line						Hot Gas line						
		R134a	R22	R404A	R407C	R410A	R507	R134a	R22	R404A	R407C	R410A	R507	R134a	R22	R404A	R407C	R410A	R507	
Diaphragm Pilot Operated	1164/3																			
	1168/3	13.6	14.6	9.5	13.8	13.7	9.2	1.51	2.04	1.78	1.82	2.40	1.78	6.8	8.6	7.7	9.3	10.9	7.6	
	1168/M10																			
	1170/4	37.4	40.3	26.2	37.9	37.8	25.3	4.16	5.61	4.91	4.99	6.60	4.91	18.7	23.8	21.1	25.6	29.9	21.0	
	1170/5	44.4	47.8	31.1	45.0	44.8	30.0	4.93	6.66	5.82	5.92	7.83	5.82	22.2	28.2	25.1	30.3	35.5	24.9	
	1178/M12																			
	1178/4	37.4	40.3	26.2	37.9	37.8	25.3	4.16	5.61	4.91	4.99	6.60	4.91	18.7	23.8	21.1	25.6	29.9	21.0	
	1178/5	44.4	47.8	31.1	45.0	44.8	30.0	4.93	6.66	5.82	5.92	7.83	5.82	22.2	28.2	25.1	30.3	35.5	24.9	
	1190/5	64.6	69.5	45.2	65.5	65.2	43.7	7.2	9.7	8.5	8.6	11.4	8.5	32.3	41.0	36.5	44.2	51.7	36.3	
	1190/6	81.6	87.8	57.1	82.7	82.4	55.2	9.1	12.2	10.7	10.9	14.4	10.7	40.8	51.8	46.1	55.8	65.3	45.8	
	1198/5	64.6	69.5	45.2	65.5	65.2	43.7	7.2	9.7	8.5	8.6	11.4	8.5	32.3	41.0	36.5	44.2	51.7	36.3	
	1198/6	81.6	87.8	57.1	82.7	82.4	55.2	9.1	12.2	10.7	10.9	14.4	10.7	40.8	51.8	46.1	55.8	65.3	45.8	
1198/7	96.9	104.3	67.8	98.2	97.9	65.6	10.8	14.5	12.7	12.9	17.1	12.7	48.5	61.6	54.7	66.2	77.5	54.4		
1178/9	170.0	183.0	119.0	172.3	171.7	115.0	18.9	25.5	22.3	22.7	30.0	22.3	85.0	108.0	96.0	116.2	136.0	95.4		
Piston Pilot Operated	1134/3																			
	1138/3	17.0	18.3	11.9	17.2	17.2	11.5	1.89	2.55	2.23	2.27	3.00	2.23	8.5	10.8	9.6	11.6	13.6	9.5	
	1138/M10																			
	1140/4	40.8	43.9	28.6	41.4	41.2	27.6	4.54	6.12	5.35	5.45	7.20	5.35	20.4	25.9	23.0	27.9	32.6	22.9	
	1140/5	51.0	54.9	35.7	51.7	51.5	34.5	5.67	7.65	6.69	6.81	9.00	6.69	25.5	32.4	28.8	34.9	40.8	28.6	
	1148/M12																			
	1148/4	40.8	43.9	28.6	41.4	41.2	27.6	4.54	6.12	5.35	5.45	7.20	5.35	20.4	25.9	23.0	27.9	32.6	22.9	
	1148/5	51.0	54.9	35.7	51.7	51.5	34.5	5.67	7.65	6.69	6.81	9.00	6.69	25.5	32.4	28.8	34.9	40.8	28.6	
	1150/5	64.6	69.5	45.2	65.5	65.2	43.7	7.2	9.7	8.5	8.6	11.4	8.5	32.3	41.0	36.5	44.2	51.7	36.3	
	1150/6	81.6	87.8	57.1	82.7	82.4	55.2	9.1	12.2	10.7	10.9	14.4	10.7	40.8	51.8	46.1	55.8	65.3	45.8	
	1158/5	64.6	69.5	45.2	65.5	65.2	43.7	7.2	9.7	8.5	8.6	11.4	8.5	32.3	41.0	36.5	44.2	51.7	36.3	
	1158/6	81.6	87.8	57.1	82.7	82.4	55.2	9.1	12.2	10.7	10.9	14.4	10.7	40.8	51.8	46.1	55.8	65.3	45.8	
	1158/7	96.9	104.3	67.8	98.2	97.9	65.6	10.8	14.5	12.7	12.9	17.1	12.7	48.5	61.6	54.7	66.2	77.5	54.4	
	1198/9	170.0	183.0	119.0	172.3	171.7	115.0	18.9	25.5	22.3	22.7	30.0	22.3	85.0	108.0	96.0	116.2	136.0	95.4	
	1178/11	272.0	292.8	190.4	275.7	274.7	184.0	30.2	40.8	35.7	36.3	48.0	35.7	136.0	172.8	153.6	185.9	217.6	152.6	
	1178/13																			
1178/M42	425.0	457.5	297.5	430.8	429.3	287.5	47.3	63.8	55.8	56.8	75.0	55.8	212.5	270.0	240.0	290.5	340.0	238.5		

Standard rating conditions according to AHRI Standard 760-2007

Condensing temperature	110 °F	(43,3 °C)
Liquid temperature	100 °F	(37,8 °C)
Subcooling	10 °R	(5,5 °K)
Evaporating temperature	40 °F	(4,4 °C)
Suction temperature	65 °F	(18,3 °C)
Superheating	25 °R	(13,9 °K)
Discharge temperature	160 °F	(71,1 °C)



APPLICATION

For the normally closed solenoid valves, previously shown in this Handbook, Castel puts the following types of coils at disposal of its own customers:

- coils series HM2, only for A.C. (catalogue numbers 9100 - 9105).
- coils series CM2, only for A.C. (catalogue number 9110).
- coils series HM3, either for A.C. or for D.C. (catalogue number 9120).
- coils series HM4, only for A.C. (catalogue number 9160).

For the normally open solenoid valves, always shown in this Handbook, the customer's selection must compulsorily apply to the coils series HM3 - D.C. .

For applications of the NO solenoid valves with a voltage supply of 220 V AC, Castel has designed a specific coil at 220 V RAC (code 9120/RD6) that must be used solely with the 220 V AC connector/rectifier circuit (code 9150/R45).

CONSTRUCTION

Coils HM2 (9100) are class H, whereas coils CM2, HM3 and HM4 are class F, in compliance with IEC 85 standard and their construction is in compliance with EN 60730-1 and EN 60730-2-8 standards. The windings are made with copper wire, insulation class H 180 °C, in compliance with IEC 85 standard. The outer casing is provided with dielectric and waterproof resins that assure a reinforced insulation making the coils suitable for all assemblies.

Coils HM2 (9105) are class F, with UL approved EIS (Electrical Insulation System), and their construction is in compliance with UL 429 Standards.

Protection against electric contacts is class I for all the coils. Therefore,

for safety purposes, coils must be effectively connected to an earthing system. Rubber gaskets on the upper and lower ends of coil ensure moisture protection of winding.

Coils HM2 and HM3 may be joined to all connectors produced by Castel except type 9155/R01; protection degree guaranteed by this system, coil (HM2, HM3) + connector, is IP65 according to EN 60529.

Coils HM4 must be preferably used with connector type 9155/R01; protection degree guaranteed by this other system, coil HM4 + connector 9155/R01, is IP65/IP68 according to EN 60529. Coils HM4 can be used with connectors series 9150 and 9900 too; protection degree guaranteed by this system is IP65.

Either the terminals of coils series HM2 and HM3 or the ones of coils series HM4 consist of two Faston line connections plus one Faston earthing connection. Coil type CM2 has a pre-assembled cable (length 1 meter).

The coils are designed for continuous use. The solid construction of these coils is suitable for heavy-duty applications in refrigerant systems. The maximum ambient temperature for all coils is 50 °C.

ELECTRIC TYPE APPROVAL

Coils series 9100, 220/230 V AC and 240 V AC supply, are approved by the German registration body VDE. Coils series 9105 are approved by Underwriters Laboratories Inc. of the United States. Coils series 9100, 9110 and 9160, 110 V AC, 220/230 V AC and 240 V AC supply, and coils series 9120, 220/230 V AC supply, are manufactured according to Low Voltage (LV) Directive 2006/95/EC. Coils series 9100, 9110, 9120 and 9160 are manufactured according to Electromagnetic Compatibility (EMC) Directive 2004/108/EC.

TABLE 1: General Characteristics of coils

Coil Type	Catalogue Number	Voltage [V]	Voltage tolerance [%]	Frequcy [Hz]	Connections	Protection Degree
HM2	9100/RA2	24 A.C.	+10 / -10	50 / 60	Junction box DIN 43650	IP65 EN 60529 (with junction box)
	9100/RA4	110 A.C.				
	9100/RA6	220/230 A.C.	+6 / -10			
	9100/RA7	240 A.C.	+10 / -10			
	9100/RA8	380 A.C.				
HM2 UL Recognized (File Number E243604)	9105/RA2	24 A.C.	+10 / -10	60	Junction box DIN 43650	IP65 EN 60529 (with junction box)
	9105/RA4	110/120 A.C.	+6 / -10			
	9105/RA6	220/230 A.C.				
	9105/RA7	240 A.C.	+10 / -10			
CM2	9110/RA2	24 A.C.	+10 / -10	50 / 60	Three wire cable	IP65 EN 60529
	9110/RA4	110 A.C.				
	9110/RA6	220/230 A.C.	+6 / -10			
	9110/RA7	240 A.C.	+10 / -10			
HM3	9120/RA6	220/230 A.C.	+6 / -10	50 / 60	Junction box DIN 43650	IP65 EN 60529 (with junction box)
	9120/RD1	12 D.C.	+10 / -5	-		
	9120/RD2	24 D.C.				
	9120/RD4	48 D.C.				
	9120/RD6	220 RAC				
HM4	9160/RA2	24 A.C.	+10 / -10	50 / 60	Junction box DIN 43650 or Connector 9155/R01 (1)	IP65 EN 60529 (with junction box) IP65/IP68 EN 600529 (with connector)
	9160/RA4	110 A.C.				
	9160/RA6	220/230 A.C.	+6 / -10			
	9160/RA7	240 A.C.	+10 / -10			

(1) Coil HM4 can also be coupled to connectors series 9150 and 9900, achieving a degree of protection IP65. The "versatile" degree of protection (IP65/IP68) is achieved coupling coil HM4 with four screws connector 9155/R01

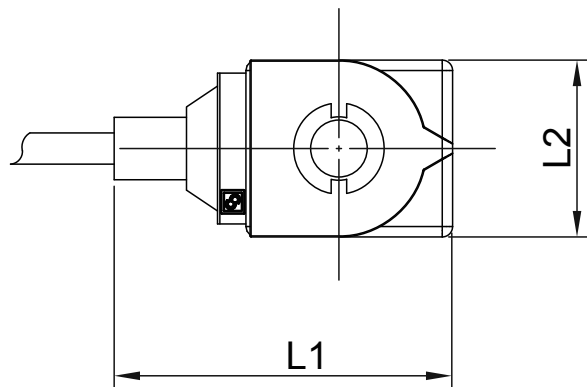
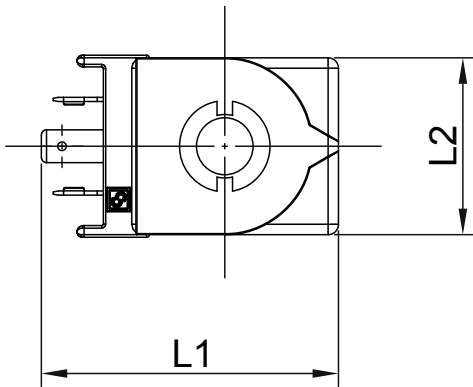
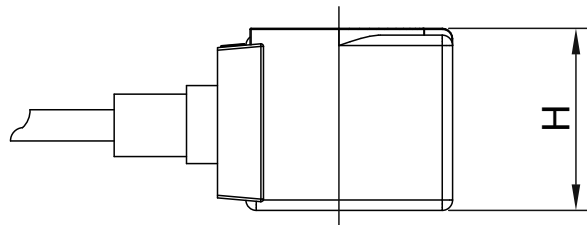
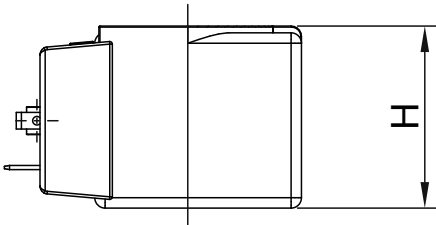

HM2

CM2

TABLE 2: Coils Consumptions, Dimensions and Weights

Coil type	Catalogue Number	Consumption at 20 °C [mA]						Dimensions [mm]			Weight [g]	
		Start			Working			L1	L1	H		
		50 [Hz]	60 [Hz]	D.C.	50 [Hz]	60 [Hz]	D.C.					
HM2	9100/RA2	920	825	-	527	420	-	57.5	34	35	165	
	9100/RA4	230	205		128	114						
	9100/RA6	140	128		68	58						
	9100/RA7	100	87		54	43						
	9100/RA8	58	51		32	23						
HM2 UL Recognized (File Number E243604)	9105/RA2	-	825	-	-	-	-	57.5	34	35	165	
	9105/RA4		205									114
	9105/RA6		105									58
	9105/RA7		87									43
CM2	9110/RA2	920	825	-	527	420	-	66.5	34	35	230	
	9110/RA4	230	205		128	114						
	9110/RA6	120	105		68	58						
	9110/RA7	100	87		54	43						
HM3	9120/RA6	190	160	-	110	80	-	82	61	35	470	
	9120/RD1	-	-	1720	-	-	1720					
	9120/RD2			900			900					
	9120/RD4			460			460					
	9120/RD6			93			93					
HM4	9160/RA2			1490			1320	-	700	530	-	63
	9160/RA4	330	300	156	118							
	9160/RA6	162	142	76	57							
	9160/RA7	147	130	70	53							

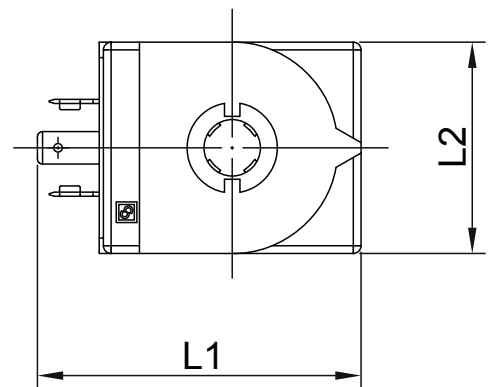
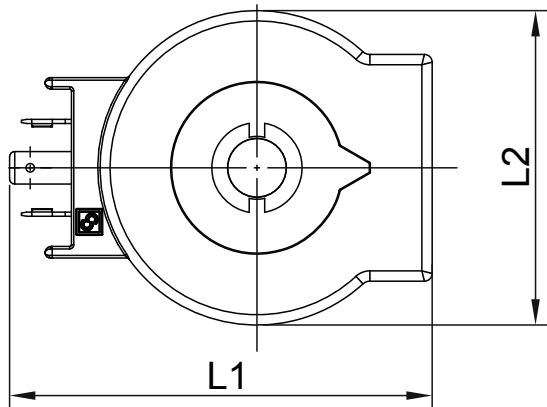
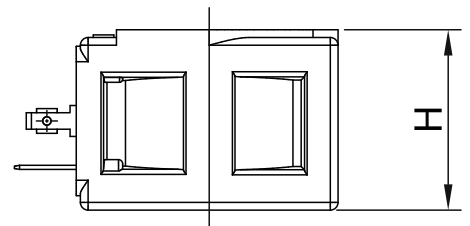
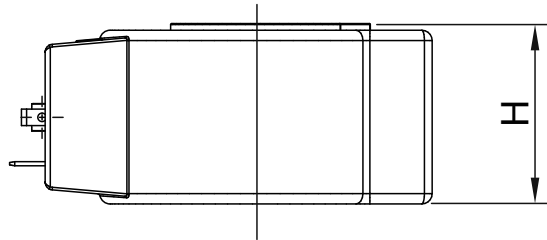

HM3

HM4

The junction boxes 9150, DIN 43650 standardized, represent an effective system for the connection of the coil to the supply circuit, thus ensuring safety also in the presence of moisture.

These junction boxes, according to assembly requirements, allow choosing the position of outer casing compared to inner terminal block. The gland nut of casing is suitable to receive cables with an external diameter of $6 \div 9$ mm and is provided with a self-locking device. Cables sized $3 \times 0,75$ mm² are to be preferred.

The junction boxes series 9900 are available with cabled core of different length. In this case, it is not possible to change the position of casing compared to terminal block.

Both the two types offer a protection degree IP65 against dust and water, according to EN 60529, when correctly installed with the proper gaskets, which are supplied as standard.

Castel developed specific junction boxes, series 9155, suitable for use on those refrigerating systems working in heavy duty environments, for example:

- exposition to the atmospheric conditions
- rooms with high moisture degree
- cyclic condensing / evaporating on the valve

- cyclic icing / defrosting on the valve

These junction boxes, according to assembly requirements, allow choosing the side position of outer casing compared to inner terminal block; but it is not possible to point the cable upwards. The gland nut of casing is suitable to receive cables with an external diameter of $6 \div 9$ mm and is provided with a self-locking device. Cables sized $3 \times 0,75$ mm² are to be preferred for these junction boxes too.

The junction boxes series 9155 offer a protection degree IP65/IP68 against dust and water, according to EN 60529, when correctly installed with the proper gaskets, which are supplied as standard.

The junction box 9150/R45 is equipped with a full-wave bridge rectifier plus VDR for protection. The VDR device, Voltage e-Dependent-Resistor, is a special type of resistor, placed in parallel to the coil; its purpose is to protect the diodes and the coil from any excessive voltage generated within the ac supply circuit.

WARNING: junction box 9150/R45 must be solely used with coil 9120/RD6 (220 V RAC). The wrong use of these junction boxes with other types of Castel coils takes quickly to the destruction of the coil.

TABLE 3: General Characteristics of connectors

Catalogue Number	Supply Voltage [V]		Cable length [m]	Cable thickness [mm ²]	Standard	Degree of protection	Class of insulation
	Nominal	Maximum					
9150/R02	-	-	-	-	DIN 43650	IP65 EN 60529	Group C VDE 0110-1/89
9150/R45	220 A.C.	250 A.C.					
9900/X66	-	-	1	3 x 0,75			
9900/X84			1.5				
9900/X73			2				
9900/X55			3				
9900/X54			5				
9155/R01	-	-	-	-			
9155/R02			1		3 x 0,75		

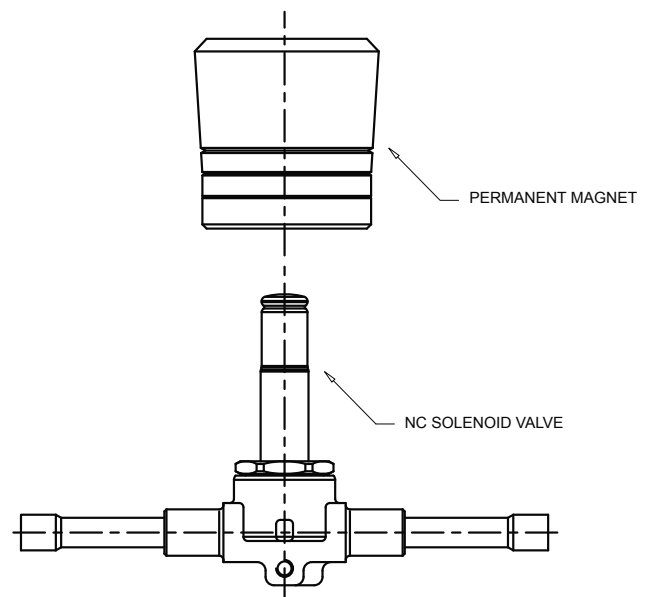

APPLICATION

Castel supplies to its customers the permanent magnet code 9900/X91 for the normally closed solenoid valves, shown in this chapter. This product can be used during brazing of the valve copper connections to the plant pipes; slipping it on the armature, instead of the coil, it allows the protective gas (nitrogen) flowing and avoids any damage to the plunger gasket and to the diaphragm.

CONSTRUCTION

The main parts of the permanent magnet code 9900/X91 are made with the following materials:

- three rings of anisotropic ferrite
- anodized aluminum for the body

